

Mud Cleaner

- Long service life
- Small separation point



Mud Cleaner

Mud Cleaner is the second class and the third class solids control equipment which is the newest type to treat the drilling fluid. At the same time Mud cleaner has the higher cleaning function compared with separated desander and desilter. In addition to the reasonable design process, it equals another **shale shaker**. TR mud cleaner structure is compact, it occupies small space and the function is powerful. Mud cleaner is the ideal device of the second class and the third class solid control to treat the drilling mud.

- Long service life
- Small separation point
- Lower blocks

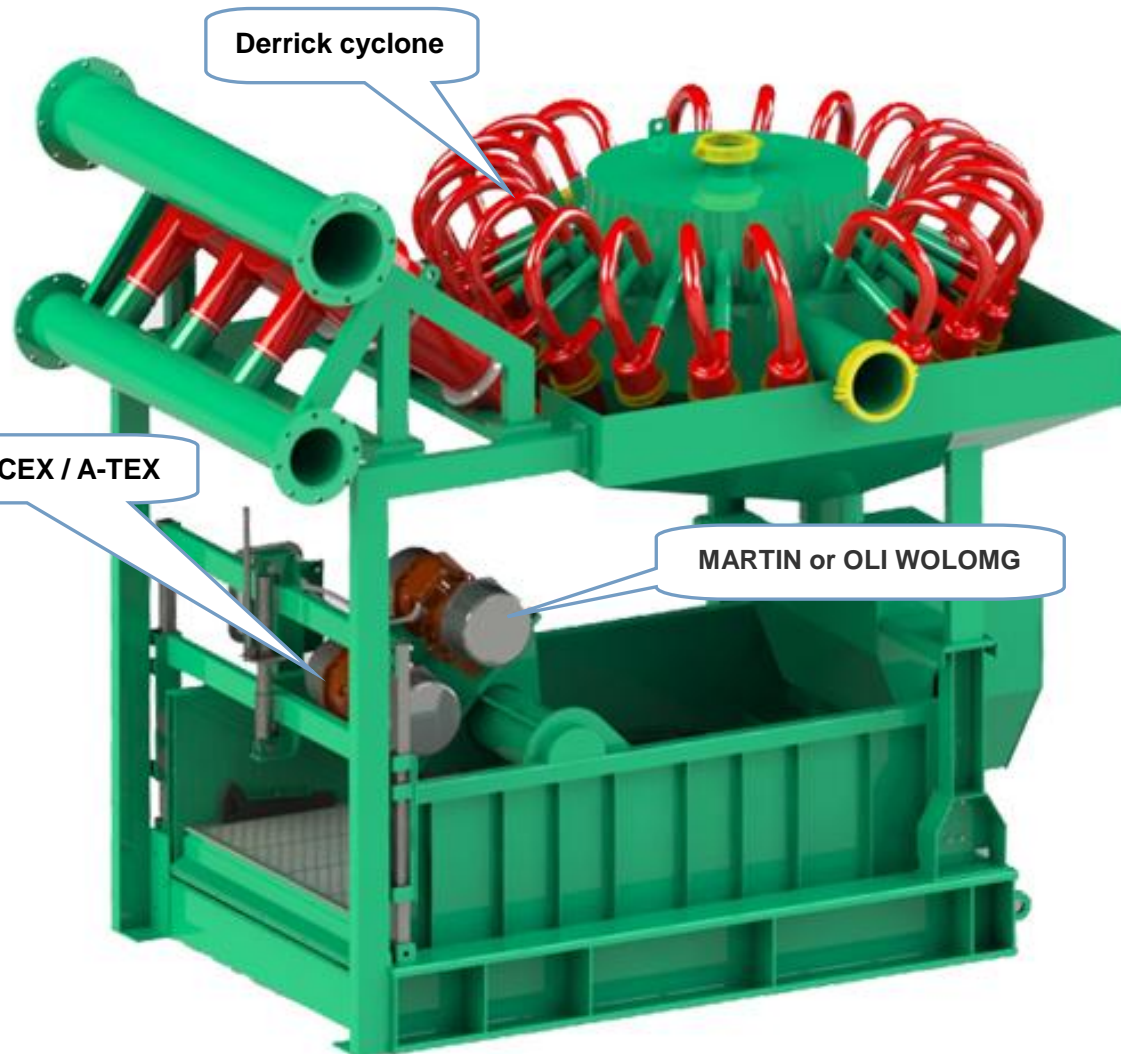

Why choose TR Mud Cleaner

- 100% polyurethane or high chromium cast iron cyclone, long life, clamp easy for maintenance.
- .Flexible choice of desanding cyclones specifications and quantity. Desanding cyclones specification of 8-inch and 10-inch. Each 8-inch capacity of desanding cyclones to 60 cubic, capacity of 10-inch cyclone 500GPM.

Mud Cleaner Parameter

Model	TRQJ200X1S-100X4N	TRQJ200X2S-100X8N
Capacity	60m ³ /h	120m ³ /h
Desander Cyclone Specs	8in	8in
Desander Cyclone Qty	1	2
Desilter Cyclone Specs	4in	4in
Desilter Cyclone Qty	4	8
Working Pressure	0.25-0.4mpa	0.25-0.4mpa
Inlet Size	DN125	DN150
Outlet Size	DN150	DN200
Separation Point	15-44	15-44
Bottom Shaker	TRTS60	TRZS752
Dimension	1510X1160X2000	1835X1230X1810
Weight	600kg	980kg

Model	TRQJ250X2S-100X12N	TRQJ250X3S-100X20N
Capacity	240m ³ /h	320m ³ /h
Desander Cyclone Specs	10in	10in
Desander Cyclone Qty	2	3
Desilter Cyclone Specs	4in	4in
Desilter Cyclone Qty	12	20
Working Pressure	0.25-0.4mpa	0.25-0.4mpa
Inlet Size	DN150	DN200
Outlet Size	DN200	DN250
Separation Point	15-44	15-44
Bottom Shaker	TRZS703	TRZS703
Dimension	2419X2150X2147	2419X2150X2147
Weight	2150kg	2350kg

Desander cyclone

Desander consists of three main components:Upper,middle,and lower sections .the soft orifice bushing is positioned in the tapered hole inside the orifice nut,which is threaded onto the lower section.the orifice nut is threaded onto the lower section.

by varying the apex opening,the hydrocyclone spray pattern may be adjusted during operation.turning

the orifice nut counterclockwise releases compression, allowing the apex to return to its original size.

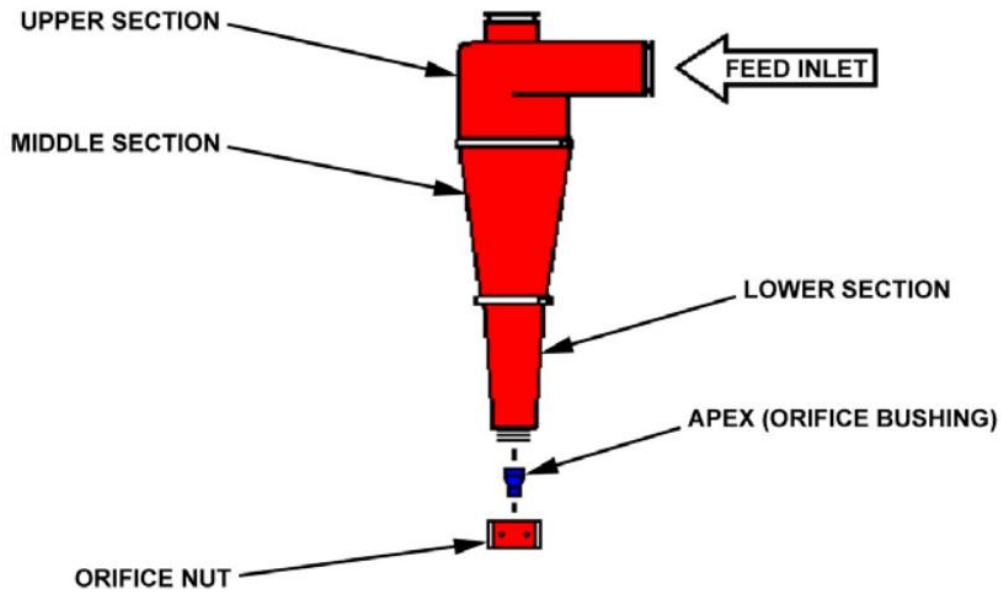

Desilter cyclone

4 in hydrocyclone desilter removes 10 to 74 micron solids from drilling fluid, the body is the main component of the 4 in hydrocyclone. a cone tip is threaded into the bottom of the body. the soft apex is positioned in the tapered hole inside the triangular nut, which is threaded onto the cone tip

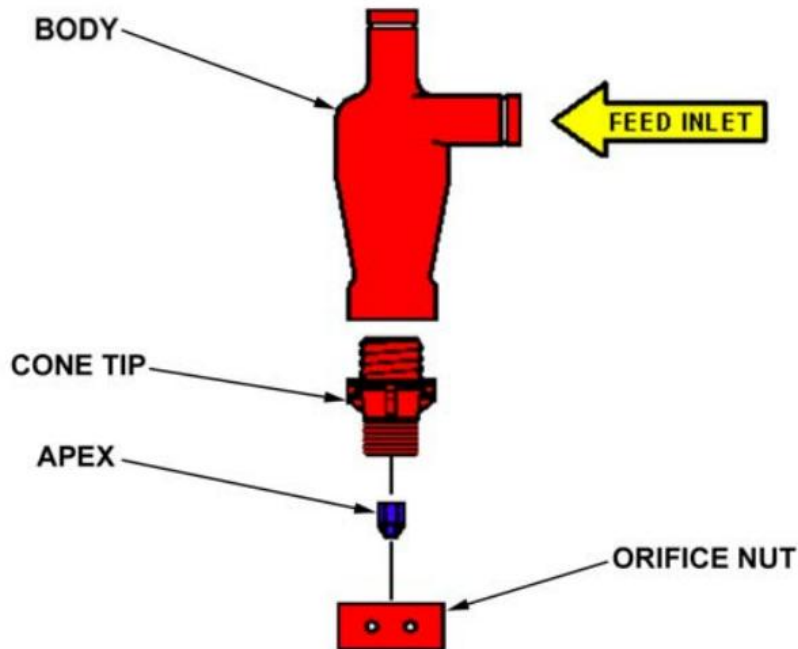

If you need to know more details about mud cleaner, then you contact us.

Company: Xian Tianrui Petroleum Machinery Equipment CO., LTD

TEL: 86-29-86332919

FAX: 86-29-86332919

E-mail: sales@trsolidscontrol.com



Model	TRQJ300X3S-100X10N
Capacity	320m³/h
Desander Cyclone Specs	12in (Swaco Cyclone)
Desander Cyclone Qty	3
Desilter Cyclone Specs	4in
Desilter Cyclone Qty	10
Working Pressure	0.25-0.4mpa
Inlet Size	DN150
Outlet Size	DN250
Separation Point	15-44
Bottom Shaker	TRZS584
Dimension	3000X1769X2250
Weight	2050kg

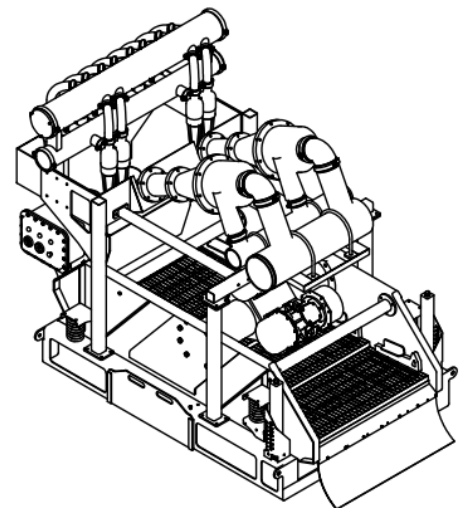
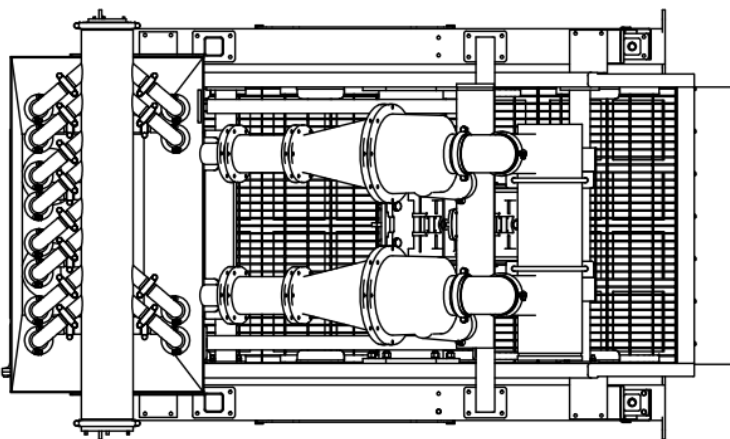
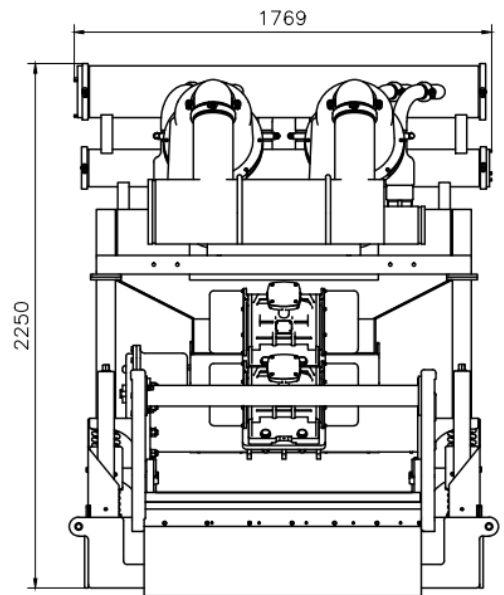
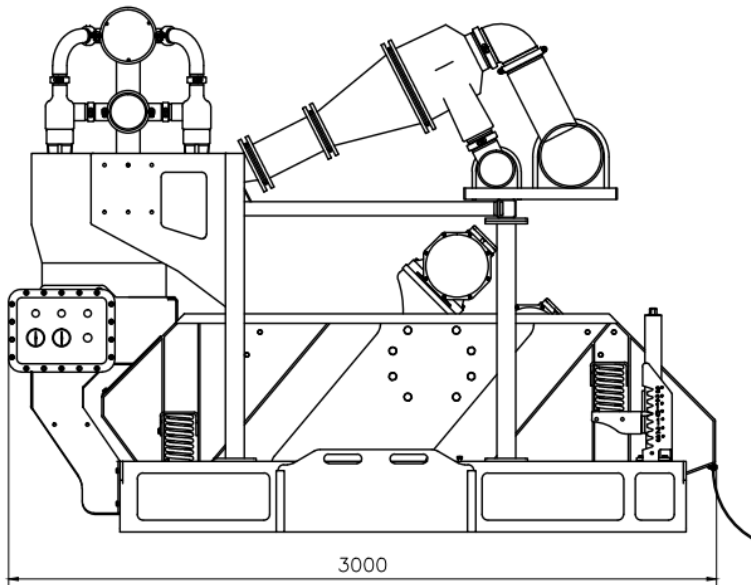

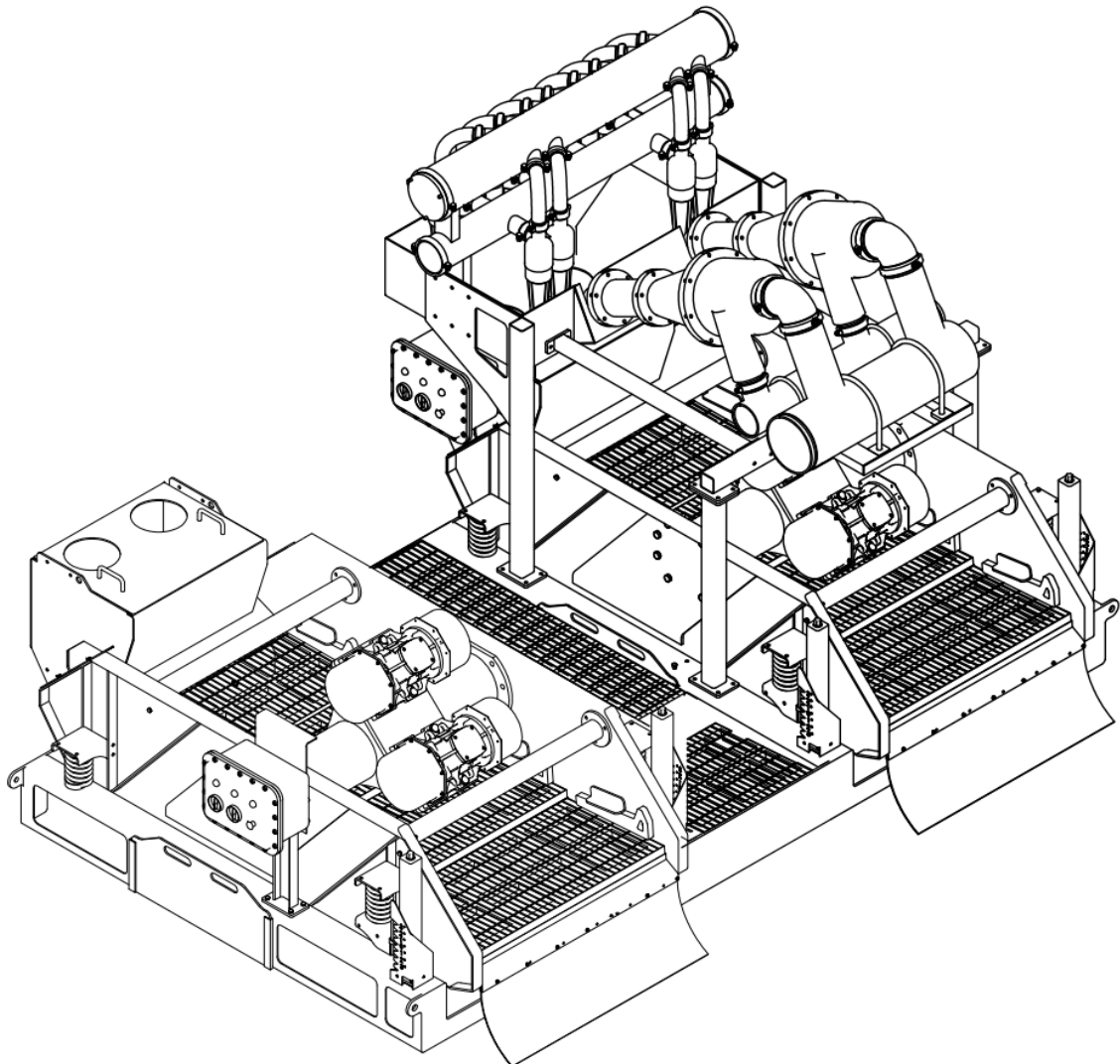

Model	TRZS584	Model	TRQJ300X3S-100X10N
Vibrating Model	Linear	Capacity	320m ³ /h
Motor Power	2×1.86KW	Desander Cyclone Specs	12in (Swaco Cyclone)
Vibrating Strength	≤7.0G	Desander Cyclone Qty	3
Amplitude	6.0~7.2mm	Desilter Cyclone Specs	4in
Capacity	527GPM	Desilter Cyclone Qty	10
Deck Adjustment	-3°~3°	Working Pressure	0.25-0.4mpa
Screen of Deck	4	Inlet Size	DN150
Electric	380V/50HZ or Customized	Outlet Size	DN250
Decibels	<85db	Separation Point	15-44
Ex Standard	ExdIIbt4	Bottom Shaker	TRZS584
Dimension	3000X1820X1300	Dimension	3000X1820X2250
Weight	1550kg	Weight	2050kg